

ENERGIA *demo*

NEW TECHNOLOGIES IN ENERGY SAVING AND EFFICIENCY

GASIFICATION AND POWER GENERATION PLANT RUN ON ALMOND SHELLS



ENERGIA NATURAL DE MÓRA, SL was commissioned by the food and farming company PERE ESCRIBÀ, SA to develop the power generation and gasification plant run on almond shells called ENAMORA. The plant, which started its industrial operation in October 1997 with 500 kW power alternative engines, has been proving to be technologically flexible and reliable and provided primary energy savings ranging over 500 Tce every year, thus preventing some 1,500 tonnes of CO₂ from being emitted into the atmosphere.

ENERGIA NATURAL DE MÓRA, SL
MÓRA D'EBRE (RIBERA D'EBRE AREA)

67

ENERGIA *demo* is a collection of technical reports on the following areas:

- ENERGY SAVING AND DIVERSIFICATION
- ENERGY EFFICIENCY
- RENEWABLE ENERGIES
- WATER SAVING
- ENVIRONMENT



Generalitat de Catalunya
Departament d'Indústria,
Comerç i Turisme
Institut Català d'Energia

introduction

As some of the industries formerly consuming almond shells as solid fuel closed down and natural gas consumption increased, a surplus of this solid fuel – not long ago a true income source in the economic balance-sheet of dry fruit producing companies – was inevitable. In this context, almond producers such as PERE ESCRIBÀ, SA company, started facing problems to make profits out of selling this fruit's shells. Furthermore, it is anticipated that

these problems would only worsen with time.

In view of the situation, in 1993, PERE ESCRIBÀ, SA studied various energy solutions to make the most out of almond shells. In 1994, their survey concluded in an ambitious research project to set up a gasification system that would allow operating with a small-sized reactor; it provided high energy performances and it was environmentally friendly. Three years afterwards, this project



Thermal conversion from solid organic matter into gas takes place in the reactor-gasifier.

Almond shell features.

	Almond shells	Assimilated vegetal waste
Humidity	10-15%	15-30%
Apparent density (kg. damp biomass/m ³)	400-425	250-280
Immediate analysis (% dry base)		
fix carbon	17-20%	5-15%
volatile gases	70-80%	40-70%
ashes	0.6-1%	10-24%
Heat power (kcal/kg.)		
high (humidity 0% humid base)	4,815	2,400
high (humidity 13.2% humid base)	4,170	to
low (humidity 0% humid base)	4,500	
low (humidity 13.2% humid base)	3,827	2,900

led to the current ENAMORA gasification facility built by ENERGIA NATURAL DE MÓRA, SL, with the support of Institut Català d'Energia. This plant generates the power required for self-consumption and it sells any surplus to the grid.

project

The gasifying process starts when motor driven shovels introduce almond shells in the main hopper. Once shells are grounded to about 4x4 mm, they are forwarded to the hoppers, which feed the reactor-gasifier directly. These consist in two groups in series, where shells are added through a mechanical system. Hoppers have some built-in sensors and some pneumatic valves, which automatically guarantee there is no shortage of material at any time. These open sequentially and stop incoming air or exhausting gas.

The reactor-gasifier where the thermal chemical reaction into fuel gas of the solid organic matter takes place is strongly protected with fire and heat-resisting material. This enables the facility to obtain high-energy transfer efficiency and to level the bed temperature throughout programmed stops. This device was also designed to guarantee that temperature was

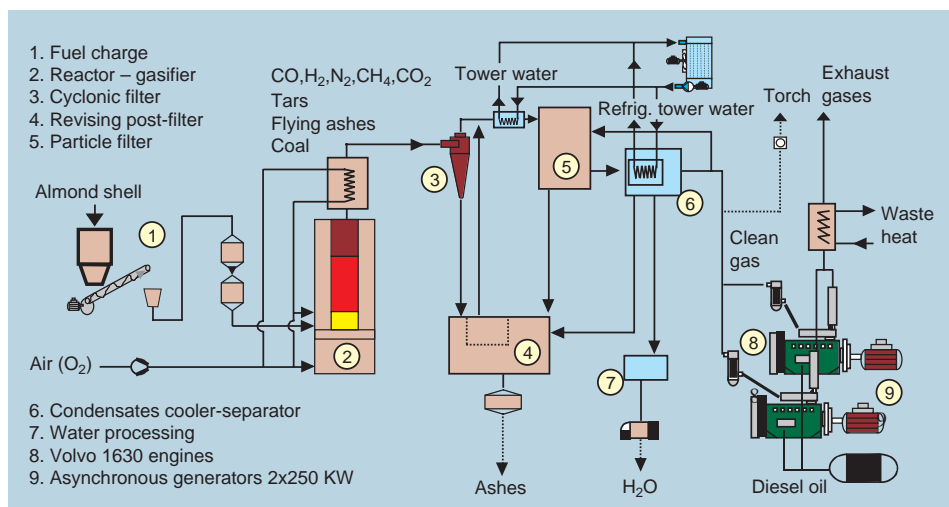

Facility process outline.

distributed alike at any time and that fuel accumulation inside was minimal.

The reactor was furnished with a balanced-pressure fluidised system, which integrates tar reduction and some built-in dispersing concentric ring injectors to ease the effectiveness of

the inert catalyst. Some sounding devices distributed along the gasifier control and regulate optimal reaction temperatures and, provide the monitoring computer with the parameters it requires to act on the frequency variator of the fuel feeding

system. A flow meter constantly measures the amount of air retained inside the reactor, which is regulated by means of a pneumatic valve.

The gasifying agent used is non-enriched ambient air, which is pre-heated up to some 250°C before it is reintroduced in the reactor in opposite direction to the gas (the latter is approximately exhausted at 700°C). This is done to optimise energy efficiency. The resulting lean gas is cleaned and cooled down so that it reaches the engine in optimal conditions.

Filtering lean gas implies eliminating solid fractions, tar remains and water excess, so that polluting emissions are largely minimised. Solid fractions, consisting in non-reacted ashes and coal micro-particles – since gasifying implies operating with an air flow –, are trapped inside within a sleeve filter and reduced to mineral ashes by means of a thermal self-oxidation process. Sleeves

cleaning bring along a proprietary system, which guarantees an efficient and safe process. Later gas cooling takes place in a gas/water interchanger (water comes from an evaporation tower so that external contributions are not required), and results in a condensate formed by remaining water from reactions and by short-chain hydrocarbons.

The process ends when lean gas is mixed with the combustion air from diesel engines, a mix that is compressed in the turbo-compressor and introduced in the combustion chamber. Keeping a certain diesel injection level ignites the mix. Diesel accounts for 5% to 8% of the energy supplied to the engine. The plant uses two land - traction VOLVO diesel engines adapted by the actual company to generate electricity and to operate with a lean gas and liquid fuel (Diesel oil) mix.

The facility was designed to



Almond shell grinder which feeds the reactor-gasifier.

operate at limited power, from 250 kW, and its priorities were safety, operation easiness and minimising maintenance costs.

results

The power generation and gasification facility concluded its testing period in October 1997. Regular industrial exploitation has not stopped since then.

The system has been proving to be extremely flexible since it allows unattended and uninterrupted 16-hour daily operation, 5 days a week. That is, the facility does not require any staff exclusively devoted to it. Daily ignition and stop operations, for instance, are fully automatic. Nominal power is reached 30 minutes after the sequence has started in the case of 8-hour stops, or 90 minutes if the stop is up to 48 hours at the most.

This way, during the 30 first months of operation, the facility was in service for over 15,000 hours



The plant has two internal combustion four-cycle engines that operate with the Dual-fuel system.

during which it generated over 6 GWh of electricity on the basis of such a renewable source as almond shells. This accounts for savings close to 1,600 Toe and for minimising emission levels almost 5,000 tonnes of CO₂. The success of this first phase made the company to be already at work to

try and duplicate the facility's power and be able to generate 1 MW of electricity by feeding it with 1 t/h of almond shells.

Once the almond shell system had proven to be flexible and reliable, ENERGIA NATURAL DE MÓRA,SL started its plans to adapt the gasifier to other types of biomass, either from natural or waste sources, organic waste such as plastics that cannot be recycled or even the fuel fraction of MSW, namely Refuse Derived Fuel (RDF).

The basic research programme that made this technology possible had a cost of over 285 million Pesetas. This development effort will enable future applications under competitive market conditions.

Plant's energy efficiency.



participants

Developers

- PERE ESCRIBÀ, SA

Ownership and exploitation

- ENERGIA NATURAL DE MÓRA, SL

Main suppliers

- Gasifier: ENERGIA NATURAL DE MÓRA, SL
- Engines: VOLVO
- Generator: ALCONZA
- Adaptation system: AUTOMECÀNICA FLORENSA

Institutional Support

- INSTITUT CATALÀ D'ENERGIA



technical characteristics

NAME: Power generation and biomass gasification plant with alternative engines.

PLACE: Móra d'Ebre (Ribera d'Ebre Area).

NUMBER OF GENERATORS: 2.

OVERALL POWER: 500 kW.

YEARLY PRODUCTION: 2 GWh.

FUEL CONSUMPTION: 2,150,000 kg of almond shells,
74,000 litres of diesel oil.

For further information, please contact:

INSTITUT CATALÀ D'ENERGIA

Departament d'Indústria, Comerç i Turisme

Av. Diagonal 453 bis, àtic

08036 BARCELONA

Tel.: +34 93 622 05 00

Fax: +34 93 622 05 01

e-mail: icaen@icaen.es



ENERGIA demo

Recent issues:

- 35 Percolating filter for wastewater treatment at a textile industry.
Multicolor Textil, SA
- 36 Efficient gas heating and cooling system.
Medical Centre at Vilassar de Dalt.
- 37 Cogeneration plant with direct use of gas.
SA REVERTÉ - RENCAT, AIE
- 38 Recycling and energy recuperation from municipal solid waste
El Maresme Integral Waste Recycling and Recovery centre.
- 39 Photovoltaic installations at a mountain hostel.
Amitges mountain hostel.
- 40 Computerised system for optimisation in real time.
Térmicas del Besós, SA
- 41 Smart, bioclimatic houses in Castelldefels.
REMMA project.
- 42 Rural photovoltaic electrification programme in La Garrotxa.
SEBA - La Garrotxa District Council.
- 43 Cogeneration plant with gas engines.
Hospital Joan XXIII Energy Group.
- 44 Solar duct for lighting and ventilation.
Santa Amàlia building.
- 45 Baix Ebre Wind Park.
PEBESA.
- 46 Electrification of 53 homes using solar and wind power.
Wind-solar hybrid plant in Polanco (Uruguay).
- 47 Building equipped with multifunctional photovoltaic modules.
"Pompeu Fabra" library in Mataró.
- 48 High performance solar installation.
CAR-CMR Sant Cugat del Vallès.
- 49 Cogeneration plant for three textile factories.
Cogeneració d'Hostalric, AIE
- 50 Llaberia Photovoltaic Power Station
Municipal borough of Tivissa (Ribera d'Ebre).
- 51 Buses fuelled by natural gas.
Barcelona.
- 52 Energy saving systems in public lighting.
El Masnou.
- 53 Centralised technical management system.
Verge de la Cinta hospital in Tortosa (Baix Ebre).
- 54 Gas engineered CHP plant.
Bariloche District Hospital (Argentina).
- 55 Combined cycle CHP plant.
Sarrió SA - Barcelona.
- 56 Combined cycle CHP plant.
Alier SA - Energética de Roselló AIE.
- 57 CHP Absorption plant.
Bellvitge health and university centre.
- 58 Public lighting management.
Municipality of Gualaguaychú (Argentina).
- 59 New technology furnace.
Vidrierías Masip. Cornellà de Llobregat.
- 60 Solar thermal energy in a municipal swimming pool.
Club Natació Terrassa.
- 61 Les Colladetes Wind Park.
Enervent SA. El Perelló (Baix Ebre).
- 62 Trucafort Wind Park.
SEESA. El Pradell de la Teixeta and la Torre de Fontaubella (Priorat Area), Colldejou and l'Argentera (Baix Camp Area).
- 63 Independent Energisation Programme through Renewables.
SEBA. Montseny Nature Park (Vallès Oriental Area).
- 64 Natural gas operated CHP-ABSORPTION station.
University Hospital Germans Trias i Pujol. Badalona (Barcelonès Area).
- 65 Vehicle run on Liquefied Natural Gas (LNG).
CESPA. Barcelona (Barcelonès Area).
- 66 Electrosolar vehicle prototype.
Universitat Politècnica de Catalunya. Barcelona (Barcelonès Area).